

BREEDER BEDDING

PRODUCT DESCRIPTION

Spanvall BREEDER BEDDING is a mixture of softwood shavings and plantfibre. The particle size is a unique composition and the product has been sieved several times in order to obtain an optimal absorption ability.



100 % dust free
(controlled degree
of moisture)

**High absorption
of ammonia**

**Reduces
heavy pad
scorch**

**High animal
welfare**

**High absorbency
capacity** (approx. 7-8
times its own weight)



PREPARATION

- 1** Clean and disinfect the house



- 2** Pre-heat the house 12-24 hours before the chicks are inserted (floor temperature is minimum 28-30 degrees Celsius)

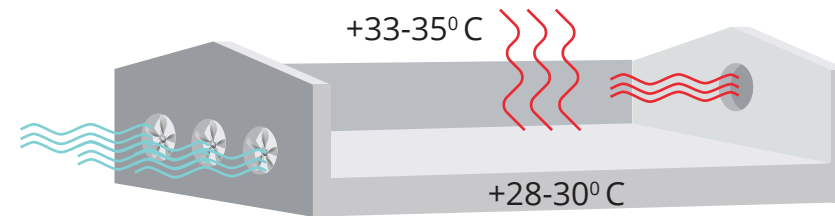

HOW TO USE

- 3** Spread approx. 2,5 kg to 3,0 kg par m² (3-4 cm)

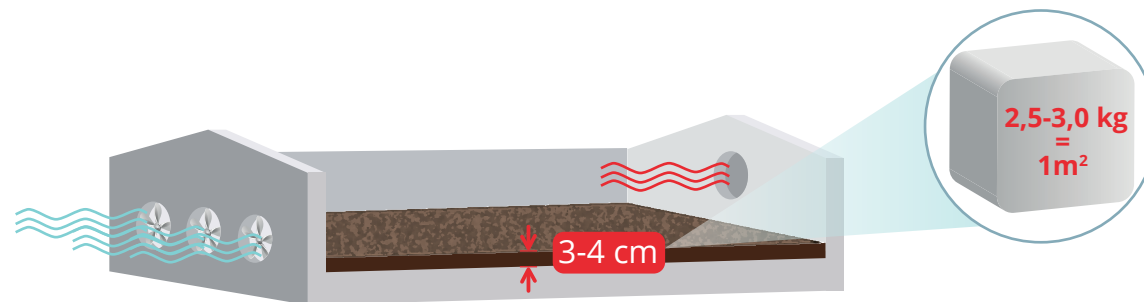

ROTATION

4 Humidity is emitted to the air

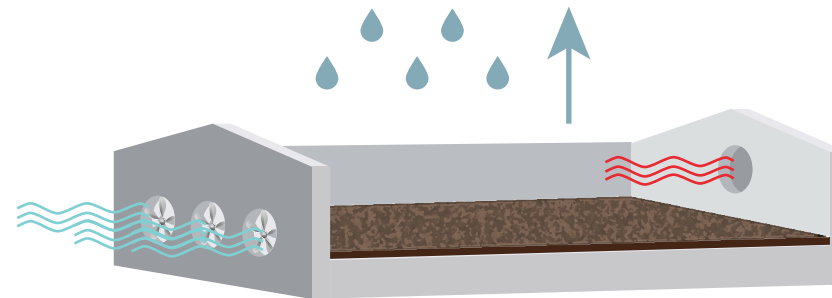

5 Absorption of ammonia

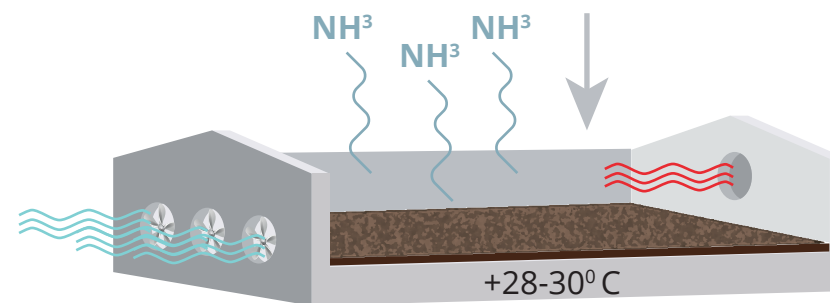

LOGISTICS

BIG BALE

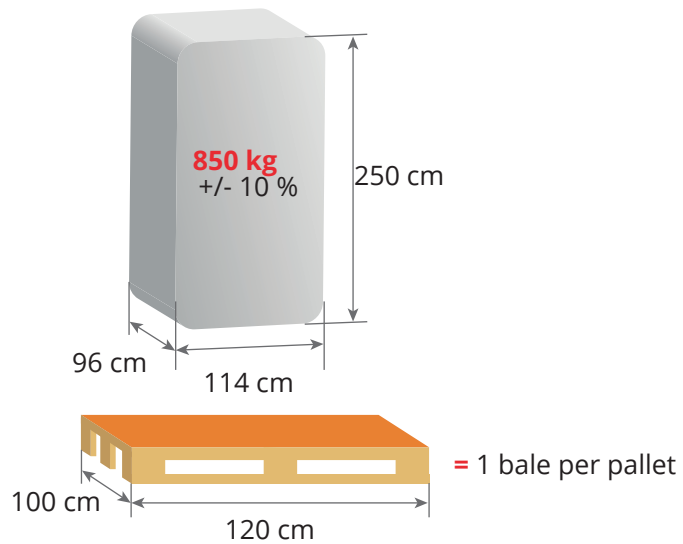

40' HC CONTAINER



TENT TRUCK

SMALL BALE

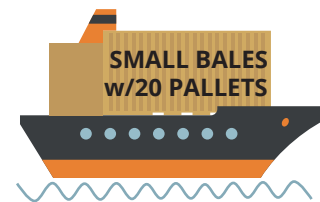
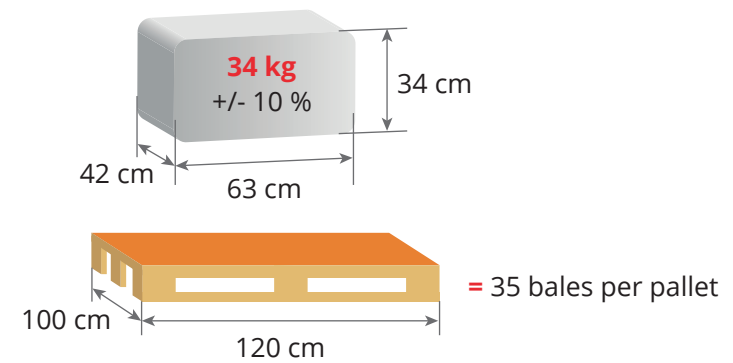

40' HC CONTAINER



TENT TRUCK