

PLANTFIBRE

PRODUCT DESCRIPTION

Plant fibre is very absorbent and stay fresh for a long time. Our natural animal bedding, plant fibre, makes an ideal choice for use with broilers. The plant fibre has an unique cellular structure which makes it very absorbent and it stays fresh for a long time. The low pH-value of the plant fibre fix the smell of ammonia. This provides an improved climate without dust and odour nuisances.

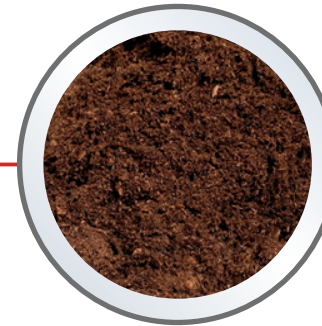

High absorbency capacity (approx. 10 times its own weight)

High absorption of ammonia

High animal welfare

100 % dust free
(controlled degree of moisture)



PREPARATION

- 1** Clean and disinfect the house



- 2** Pre-heat the house 12-24 hours before the chicks are inserted (floor temperature is minimum 28 degrees Celsius)

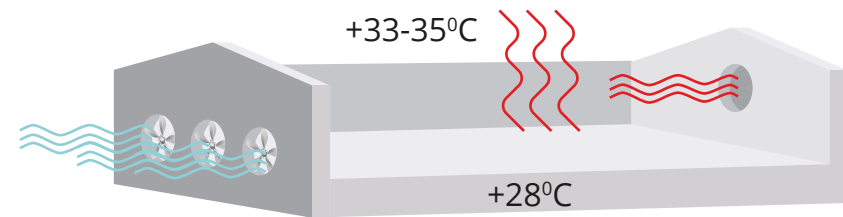

HOW TO USE

- 3** Spread 2-3 cm layer of the bedding in the house



ROTATION

4 Humidity is emitted to the air

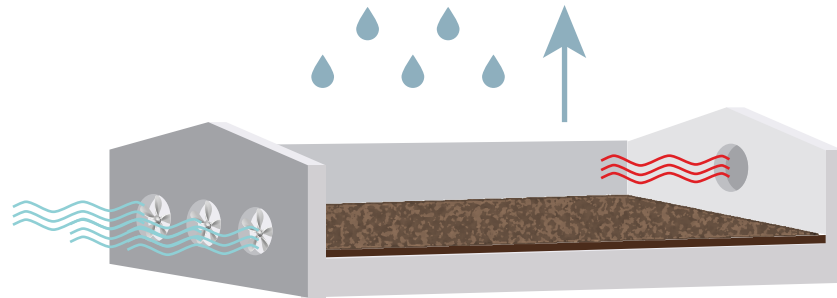

5 Absorption of ammonia

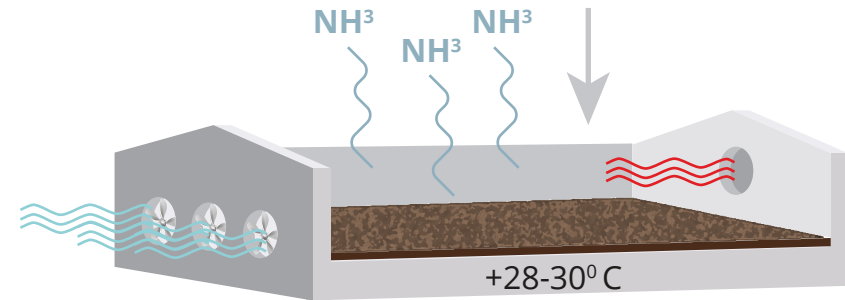

BROILER CLIMATE SETTINGS

Age days	Temperature Celsius	Maximum humidity	Minimum ventilation M ³ /h/10.000 broilers (co ²)
0	34-35	50%	600 (2000)
7	30	50%	1700 (2000)
14	28	55%	3600 (2500)
21	26	55%	6000 (3000)
28	23	60%	8000 (3000)
35	21	65%	10.000 (3000)
42	19	65%	12.000 (3000)

LOGISTICS

BIG BALE

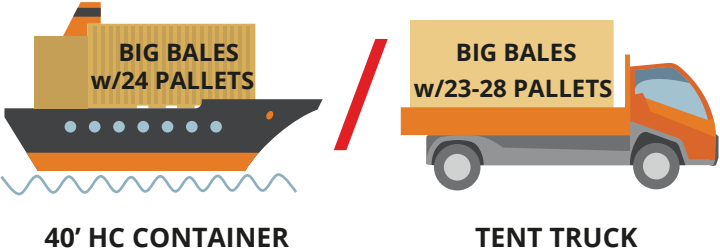
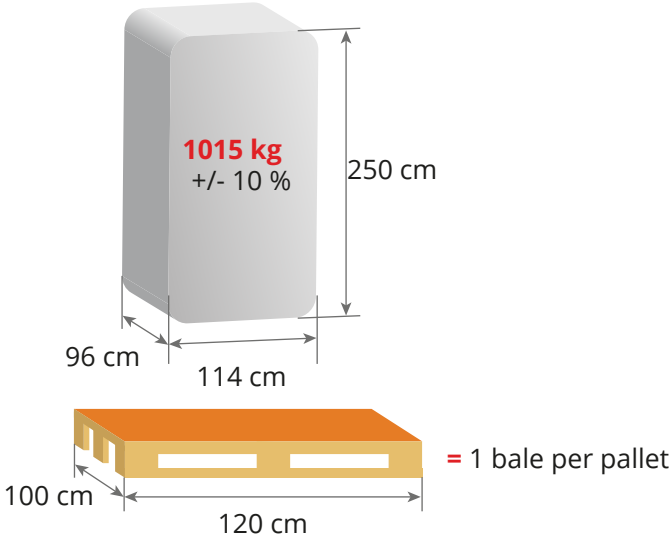

SMALL BALE

